

Cx8 2-way co-axial loudspeaker

FEATURES

The PULZ® Cx8 loudspeaker enclosure provides a versatile system that is designed for high quality distributed sound reinforcement or high performance monitoring. Using true point source coaxial technology, the Cx8 features advanced components in a flexible, multipurpose compact format that is suitable for either touring or fixed installation. The Cx8 is a passive 2-way loudspeaker enclosure containing a dome tweeter assembled in a coaxial configuration along with a 8" loudspeaker providing a conical 100° opening.

Further advantages of the coaxial approach include: single point source radiation, total wavefront coherency at all frequencies and superimposed LF/HF dispersion characteristics that are free of polar lobing effects typical of traditional horn and woofer combinations. The net result is natural, studio monitor level sound quality that is ideal for proximity use.

The new MVC, multivalent convection technology, allows the Cx8 to handle its nominal full power capacity in any working position.

APPLICATIONS

Installed PA for clubs, A/V, theatre, broadcast, etc, are the application field of Cx8.

The design and the great additional options for the Cx8, provide this speaker a simple and easy installation : One can put it on the floor, install it on a stand or fly it. Walls and ceilings are in its range of installation thanks to its optional brackets.

For music requirement, a dedicated optional processor is provided in order to optimise the Low Frequency response.

Combined with PULZ Sub 115 subwoofer , the Cx8 allows to create compact and powerful systems suitable for all indoor configuration.

The Cx8 is also ideal for distributed sound reinforcement and can be used in medium power front-of-house (FOH) applications for theatres, clubs, multi-purpose venues or corporate events.

The enclosure comprises a 45° angle side for stage monitor application and include one 35mm built in stand fitting.



- natural sound reproduction
- full power handling in any position due to MVC technology
- sophisticated electronic built-in protection
- point source radiation
- full range of mounting and flying accessories

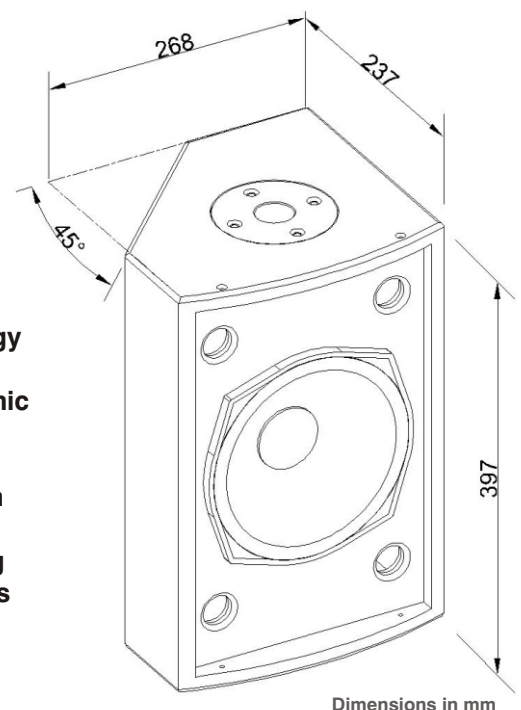

Dimensions in mm

cx8 | SPECIFICATIONS

features

Frequency range without processor (± 3 dB)
Sensitivity @1W 1m, $f > 100$ Hz
Maximum continuous level at 1m, $f > 80$ Hz
Nominal directivity @-6dB

low section

70 Hz to 1745 Hz
94 dB SPL
111 dB SPL
100° conical

high section

1745 Hz to 20 kHz
94 dB SPL
111 dB SPL
100° conical

components

Transducers

1 x 8" weatherproof
loudspeaker

1" fabric dome
coaxially mounted

Type of load

Bass reflex

conical horn

power

Recommended amps

100 to 200 W into 8 Ohms

Peak

400 W

AES

160 W

construction & characteristics

Cabinet

15mm plywood with internal reinforcements

Crossover

Air core inductors, MKP capacitors, wirewound resistors

Circuit protection

Active internal compressor limiter circuit

Finish

Gray, impact resistant structured coating

Protection grill

Acoustically transparent perforated steel, 1.5mm thick

Grill back-up

Gray, woven, heavy duty fabric

Connectors

2 x 4 sq mm push type spring loaded connector

Mounting on stand

1 x 35 mm built in stand fitting

Dimensions (H x W x D)

15.6" x 10.5" x 10.1" (397 x 268 x 257 mm)

Net unit weight

7.5 kg

Gross weight, packed

8.5 kg

directivity

0°, 10°, 20°, 30°, 40°, 50°, 60°, 70°, 80°, 90°. Average H x V

